

**15.8.2 Qualifications.** The referee, starter, and chief finish judge shall be certified by an international or national governing body for athletics. The minimum standard for other officials is prior experience at their positions; however, it is recommended that the other officials be certified by an international or national governing body for athletics.

**15.8.3 Uniforms.** Officials shall wear either a uniform provided by the competition host or the customary uniform of the official's home country.

## PART 16: TRACK & FIELD TECHNICAL RULES: FIELD EVENTS

### 16.1 ELIGIBILITY

**16.1.1 Age divisions.** Field events may be offered in the Futures (6 years and younger), Junior (three subdivisions of 7-9, 10-12, and 13-15 years), Open (any age), and Masters (35 years and older) Divisions. Athletes who choose to compete in the Open Division may not compete in the same event (e.g., shot put) in another age division.

**16.1.2 Sex divisions.** Separate events shall be held for males and females in all field events.

#### 16.1.3 Classifications

**16.1.3.1 World Dwarf Games.** The IDAF upper-body classification system shall be used in Open and Masters Division field events. The IDAF juniors division classification system shall be used in juniors division events. Refer to Part 2 of this rule book for further information.

**16.1.3.2 Other IDAF sanctioned or approved competitions.** Use of classifications at other IDAF sanctioned or approved events is at the discretion of the competition host.

**16.1.3.3 IPC sanctioned or approved competitions.** The International Paralympic Committee (IPC) classification system may be substituted for the IDAF upper-body system when IDAF events are sanctioned or approved by IPC.

**16.2 EVENTS.** The following events may be offered at IDAF sanctioned or approved meets.

	Futures 6 & younger	Juniors 7-9	Juniors 10-12	Juniors 13-15	Open Class 1, 2, 3	Masters 35 & older
<b>Flippy Flyer Throw</b>	X					
<b>Frisbee Throw</b>	X	X	X			
<b>Tennis Ball Throw</b>	X	X				
<b>Softball Throw or Cricket Ball Throw</b>		X	X			

	Futures 6 & younger	Juniors 7-9	Juniors 10-12	Juniors 13-15	Open Class 1, 2, 3	Masters 35 & older
Discus			X	X	X	X
Javelin			X	X	X	X
Shot Put			X	X	X	X

## 16.3 RULES

### 16.3.1 Flippy flyer, frisbee, tennis ball, softball, and cricket ball throw

**16.3.1.1 Number of throws.** Each competitor shall have three throwing attempts. The furthest legal throw shall be the athlete's result.

**16.3.1.2 Starting position.** The athlete shall stand with feet completely inside the circle. If the athlete is a wheelchair user, a sitting position may be used where no part of the athlete or wheelchair is on or outside the circle. Mobility devices such as canes or walkers may be used for balance if the athlete generally relies upon those mobility devices for activities of daily living.

**16.3.1.3 Throwing technique.** The athlete shall throw the implement with one hand. No run-ups are allowed.

**16.3.1.4 Legal throws.** The athlete must remain standing (or sitting) with feet completely inside the circle. The frisbee/ball must land between the two white sector lines marked on the field. If the athlete steps on or outside the circle, or if the frisbee/ball lands outside the sector lines, the throw will not be measured and a "no throw" shall be recorded.

**16.3.1.5 Measurement.** The throwing distance shall be measured to the nearest centimeter from the front of the throwing circle to the point where the frisbee/ball landed.

**16.3.1.6 Referee's decision.** The referee's decision is final.

**16.3.2 Discus, javelin, and shot put.** Section 4 of the current International Paralympic Committee rules pertaining to the discus throw, javelin throw, and shot put (<http://ipc-athletics.paralympic.org/>) shall be observed.

## 16.4 COMPETITION PROCEDURES

**16.4.1 Warm-up/practice opportunities.** The throwing event area shall be available for warm-up at least 30 minutes prior to each session of competition. The competition host shall determine the schedule and location of additional practice time opportunities.

**16.4.2 Check-in procedures.** The competition host shall determine check-in procedures.

### 16.4.3 Competition format

**16.4.4.1 Divisions.** The order of events shall be specified in the information provided to athletes in advance of the entry deadline. Male and female athletes from different age groups and different classifications may be combined in

flights for efficiency; however, their results shall be kept separately for awards purposes.

**16.4.4.2 Flights.** One flight consists of each competitor in a division/event having one opportunity to throw. All athletes assigned to a flight shall complete one throw before the next round begins. The order of competitors within a flight shall be determined by random draw.

**16.4.4.3 Number of throws.** When competition is divided into preliminary and championship flights, all athletes shall have three throws in the preliminary flight, after which the top eight competitors shall have an additional three throws in the championship flight.

**16.4.4.4 Throwing procedures**

- The official shall record attendance at the beginning of the competition.
- The official shall indicate the throwing order to all the athletes and shall announce after each throw the next two athletes.
- An athlete shall have 2 minutes to complete a throw after her/his name has been called.
- Athletes must wait for the signal from the official before entering the throwing area.
- Athletes must respect health and safety when other athletes are throwing.
- Noise must be kept to a minimum and mobile devices switched off or set on silent mode.

**16.4.4 Results**

**16.4.5.1 Measurement accuracy.** Measurement shall be to the nearest centimeter, and shall be rounded down to the next lower gradation. Steel measuring tapes shall be properly calibrated according to manufacturer's specifications.

**16.4.5.2 Place finishes.** Place finishes shall be determined by the distances of the athletes' longest legal throws. The winner of an event shall be the athlete with the longest legal throw. Athletes' second longest legal throws will be compared in the event of a tie.

**16.4.5.3 Results according to IDAF and IPC classifications.** If field events are sanctioned or approved by the International Paralympic Committee (IPC), the meet host shall prepare two sets of results based upon the same performances, one based upon athletes IDAF upper body classifications and one based upon IPC field classifications.

**16.4.5 Awards.** At the discretion of the competition host, when sex and/or classification divisions are combined, separate awards may be presented to athletes in the different divisions (e.g., when Class 1 and Class 2 players compete in the same event, awards may be presented to the highest ranking players in each class).

**16.5 FACILITIES**

**16.5.1 Flippy flyer, frisbee, tennis ball, softball, cricket ball, and shot put events.** A shot put ring with the dimensions specified by International Paralympic Committee rules

(<http://ipc-athletics.paralympic.org/>) shall be used as the throwing circle for tennis ball, softball, cricket ball, and shot put events. Sector lines shall be clearly visible.

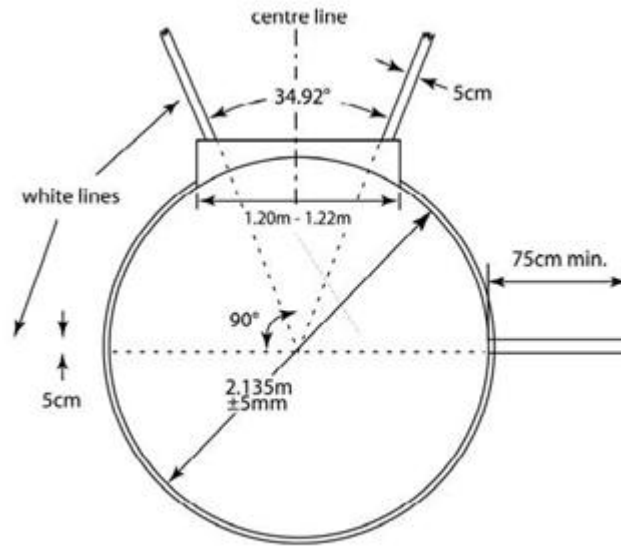

Figure 8 – Layout of Shot Put circle

**16.5.2 Discus.** A discus ring with the dimensions specified by International Paralympic Committee rules (<http://ipc-athletics.paralympic.org/>) shall be used as the throwing circle for the discus event. Sector lines shall be clearly visible.

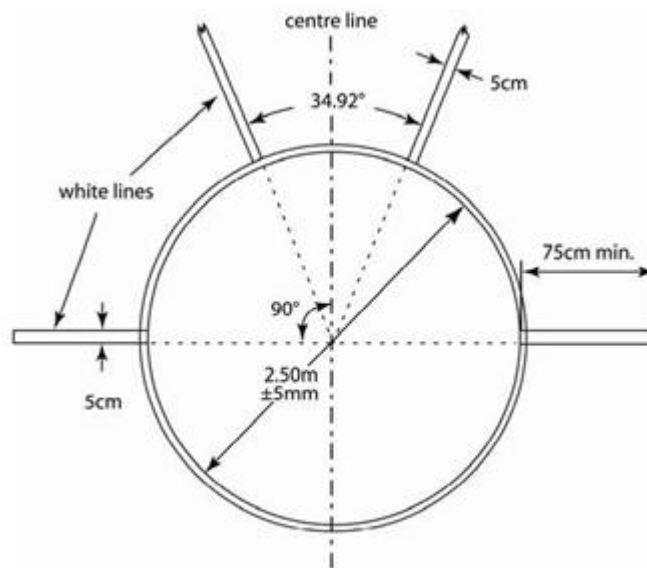

Figure 9 – Layout of Discus circle

**16.5.3 Javelin.** A javelin runway with the dimensions specified by International Paralympic Committee rules (<http://ipc-athletics.paralympic.org/>) shall be used as the performing area for the javelin event. Sector lines shall be clearly visible.

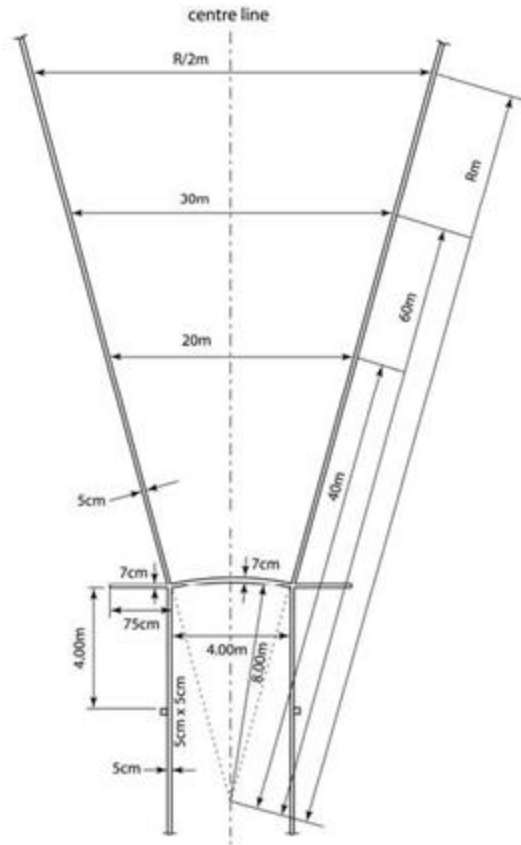

Figure 10 – Javelin Throw runway and landing sector (not to scale)

**16.5.4 Wind socks.** One or more wind socks shall be place in an appropriate position for discus and javelin events.

**16.6 EQUIPMENT**

**16.6.1 Flippy flyer.** A flippy flyer is a fabric disc 8 inches (20.3 cm) in diameter.

**16.6.2 Frisbee disc.** The disc shall be 5.11 ounces (145 gr) in weight, and 9.5 inches (24.1 cm) in diameter. This size disc is recommended for ultimate frisbee play in youth leagues.

**16.6.3 Tennis ball, softball, and cricket ball specifications**

	<b>Circumference</b>	<b>Weight</b>	<b>Other</b>
<b>Tennis ball</b>	2.500-2.625 in 6.4-6.7 cm	2.00-2.06 oz 57.7-58.5 gr	Bound 53-58 inches when dropped 100 inches to concrete
<b>Softball</b>	10.875-11.125 in 29.4-30.0 cm	5.875-6.126 oz 166.5-173.6 gr	
<b>Cricket ball</b>	8.82-9.02 in 22.4-22.9 cm	5.50-5.75 oz 156-163 gr	Leather cover

**16.6.4 Discus, javelin, and shot put.** The weights of throwing implements for the Juniors 13-15 and Open Divisions are from the International Paralympic Committee rules for field events (see Appendix, <http://ipc-athletics.paralympic.org/>). The weights of the throwing implements for Juniors 10-12 are based upon past practice in dwarf sports competitions.

	Discus		Javelin		Shot Put	
	Males	Females	Males	Females	Males	Females
<b>Juniors 10-12</b>	500 gr	500 gr	270 gr	270 gr	2.72 kg	2.00 kg
<b>Juniors 13-15</b>	1.00 kg	750 gr	400 gr	400 gr	3.00 kg	2.00 kg
<b>Open</b>	1.00 kg	750 gr	600 gr	400 gr	4.00 kg	3.00 kg
<b>Masters</b>	1.00 kg	750 gr	600 gr	400 gr	4.00 kg	3.00 kg

**16.7 UNIFORMS.** International Paralympic Committee athletics rules (<http://ipc-athletics.paralympic.org>) regarding uniforms (Rule 6 - Clothing, Shoes, and Athlete Bibs) shall apply to IDAF field event competitions.

## **16.8 OFFICIALS**

**16.8.1 IPC sanctioned or approved competition.** International Paralympic Committee athletics rules shall apply to the officiating of field events whenever the competition is IPC sanctioned or approved, including the number, qualifications, and responsibilities of officials and classifiers.

### **16.8.2 IDAF competitions**

**16.8.2.1 Minimum number.** There shall be one referee, two event assistants at the circle, and two event assistants in the field. The referee shall direct the competition, review the rules with athletes and event assistants, and adjudicate any disagreements amongst the event assistants. The two event assistants at the circle shall be located on opposite sides of the circle, and shall be watch for fouls and inspect implements for the legal mark placed at weigh-in. One of the event assistants in the field shall pull the tape through the center of the circle, and the other shall read the tape and record the measurement.

**16.8.2.2 Qualifications.** The referee shall be certified as a field official by an international or national governing body for athletics. The minimum standard for event assistants is prior experience at their positions; however, it is recommended that the event assistants be certified as a field official by an international or national governing body for athletics.

**16.8.3.3 Uniforms.** Officials shall wear either a uniform provided by the competition host or the customary uniform of the official's home country.